





Manufactured in the USA • A-1 Scaffold & Shoring, L.L.C. • Hays Kansas USA • 6760

Tabla® 

**A-1 SCAFFOLD
& SHORING, L.L.C.**



GILLESPIE PRACTICAL
TECHNOLOGIES, INC.



© 2005

**READ
INSTRUCTIONS
& DRAWINGS**



Phone: (785) 625-8581 • Toll Free: (877) 625-7510 • Fax: (785) 625-8452 • Web: TablaShoring.com

TABLA[®]



PANEL

International Patents Pending

1541 Hurontario Street, Suite 200
Mississauga, Ontario Canada L5G-3H7
Ph: (905) 844-5300 | Fax: (905) 844-5303
TablaShoring.com | Sales@TablaShoring.com

© 2014

MANUFACTURED BY

A1 SCAFFOLD &
SHORING, L.L.C.

CONCRETE PRODUCTS
DIVISION
HAYS, KANSAS U.S.A.

**SAFETY
FIRST**

Consult All Safety
Instructions And Manual

DESIGNED BY



DESIGN PRACTICE
TECHNOLOGIES INC.

TORONTO, CANADA

















The TABLA Modular Shoring System



TABLA Slab Panel

The TABLA Modular Shoring System is a high octane, high performance engineered modular panel shoring system.

Tabla offers faster erection and stripping than can ever be expected from conventional shoring systems. It begins with rigid panel construction that enhances handling. The Tabla Prop with its integrated drop-head solution, helps to ensure confidence when erecting and makes stripping effortlessly all while leaving your back shoring in place and undisturbed. All these advantages result in a high rate of production.

The Panel and Prop have been designed to form a rigid interlocking system when erected that no bracing is required. The system is also designed to have a locking key feature that can withstand near hurricane wind speeds.

The standard TABLA Modular Shoring System is a unique system erected from the working floor up to a height of 16'6"/5030. Tabla can accommodate drop beams, drop heads, and any other engineering designs that are not regular to a flat slab.

This brochure will show you the simplicity of our Shoring System as well as the minimized number of components required for the erection and dismantling process.

The simplicity of the TABLA system shown being erected, right and left, is the key to its speed and safety.

On a grid of 4'x8'/2400x1200 TABLA can support 14"/355* of concrete including live load with a safety factor of 3:1.

On a grid of 6'x4'/1800 x 1200 TABLA can support 22"/558* of concrete including live load with safety factor of 3:1.

On a grid of 4'x4'/1200 x 1200 TABLA can support 34"/863* of concrete including live load with a safety factor of 3:1.

*Prop rating at a height of 11'6"/3505



The TABLA System: Safe, Fast, Efficient



Below are the three simple steps* to erecting the TABLA Modular Shoring system from the safety of the working floor.

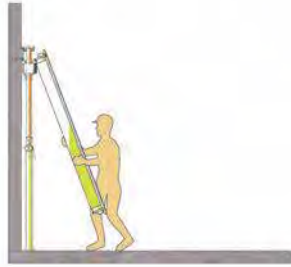

Step 1

The Panel is hung onto the Prop.

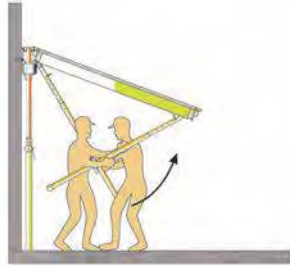

Step 2

The Panel is rotated (lifted) to the horizontal position and supported with the ADT.

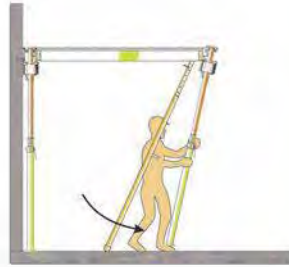

Step 3

Next the Prop is slipped into position, locking into and supporting the Panel.

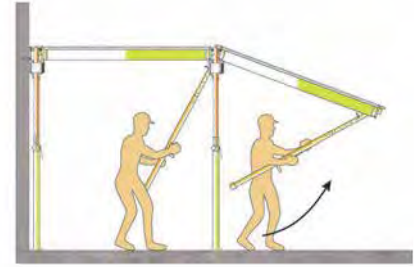

Erection continues by repeating steps 1,2 and 3

BUILD STRONG BUILD WITH QUALITY



Prop

**ADT
Tool**

The Standard TABLA Shoring System is a unique system erected from the working floor up to a height of 12'/3658. With Prop Extension the system can be erected up to a height of 16'/4877. For higher floors see the TABLA Pioneer System on page 22. TABLA Shoring can accommodate drop bands, drop heads and its design allows for all interruptions.

The TABLA Prop with its integrated Drop-head ensures ease of erection and stripping, while back propping remains undisturbed. TABLA Props are available in two sizes: 10'-0"/3280 mm and 12'-0"/3936 mm. In addition, there is a Prop Extension which, when coupled with a TABLA Prop, allows for additional height of 4'-6"/1476 mm. Our Prop features numbered adjustment holes, and an all new quick release reshore base.

The TABLA Panel features a specially designed TABLA Fastener which allows for the KD (knocked down) option for container shipping overseas. This also makes it a snap for qualified personnel to replace damaged components. The new design will work with existing TABLA components. In addition, the TABLA Panel features a powder coated, colour coded finish for quick identification between side and end rails of the panel. Simply match colours during erection.



Panel

Please contact ADSF regarding the replacement of damaged components. Always use Genuine ADSF Components; never use substitutes.

For maximum performance and detailed information, review this manual in its entirety.

* ADSF recommend a minimum of 2 operatives for the assembly.



Step 1

Step 2

Step 3

Step 4

Step 5

Step 6



Insert shows ADT inserted in panel.

The minimum formwork crew size required to erect TABLA is two men*. The illustrated assembly procedure can be started anywhere on the working floor of the job site (i.e.: at column locations, middle of bay area, etc.).

System assembly using Gate Brace*

Step 1

Extend Props to required working height and insert the Quick-Release Locking Pin.

Step 2

Prepare Bracing Gates to build an "L" shaped tower by assembling one Bracing Gate and two Props. Insert and lock the Gate Brace to the Props utilizing the attached Wedges.

Step 3

Attach a second Gate Brace at 90° to one of the props in the same manner as in Step 2.

Step 4

Tilt the TABLA assembly into the upright position and prepare to attach the third Prop to the free end of the Bracing Gate.

Step 5

Square up the "L" shaped tower (3 Props and 2 Gate Braces).

Step 6

Hang the Panel on the two Props making sure that the legs of the Panel are firmly seated in the cups of the TABLA Head Assembly. Rotate Panel to allow insertion of ADT and continue to rotate upwards.





Step 7



Step 8



Step 9



Step 10

Step 7

With the ADT seated into the Panel, step 6, rotate the Panel into the horizontal position and support the Panel until the forth Prop is installed.

Step 8

Place the fourth Prop under the Panel corner socket and seat the Panel into the Prop Head.

Step 9

Hang the next Panel, as in step 6, and swivel to horizontal.

Step 10

With the ATD seated into the Panel (step 6) and the Panel rotated into the horizontal position use the ADT to support the panel temporarily until the next 2 Props are installed.

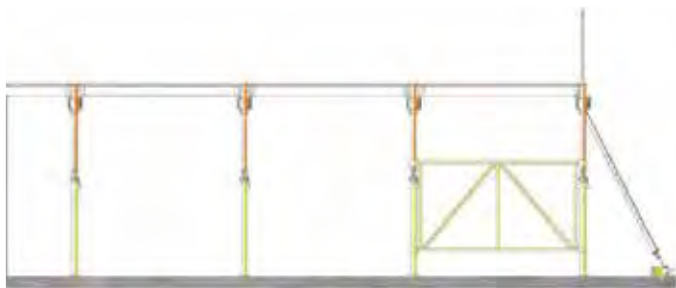

Diagonal Shear Brace is sometimes required, see your drawings

Long End Runs Brace Detail

Long end runs also require bracing (consult your layout drawings).



Blocking (typical example)

Bracing and blocking

In general, all structures require lateral bracing or lateral support. The TABLA Shoring System is no different. TABLA Shoring derives its lateral stability under load and before loading by "blocking", as construction proceeds, securely to the building's structural elements, walls, columns, cores, stairwells, etc. TABLA users can also use Wall Brackets, Wall Beams and Gate Braces. It is very important that the erector, understand the difference between blocking the system secure to the structure prior to pouring concrete, as opposed to the necessity to ensure that the system is laterally secured during the erection phase. With proper procedure TABLA Shoring can free stand during erection.

Stripping

Panel stripping

Once the pour has set, the panels can be removed for reuse without disturbing the shoring props.

Step 1

Pouring Position.

Step 2

Moving into position with ADT to unlock Panel support assembly.

Step 3

Engage the ADT.

Step 4

Panel support assembly is unlocked and has dropped away from Panel.

Step 5

Pull Panel down using ADT (both ends). Use notch and Stripping Bar if necessary to break bond.

Step 6

Panel stripped, level and engaged in all 4 cups.

Step 7

Push tail of panel up. Slide panel forward in cups clearing back cups.

Step 8

Feet remain in engaged cups. Lower (hinge) panel down.

Step 9

In position to remove Panel.

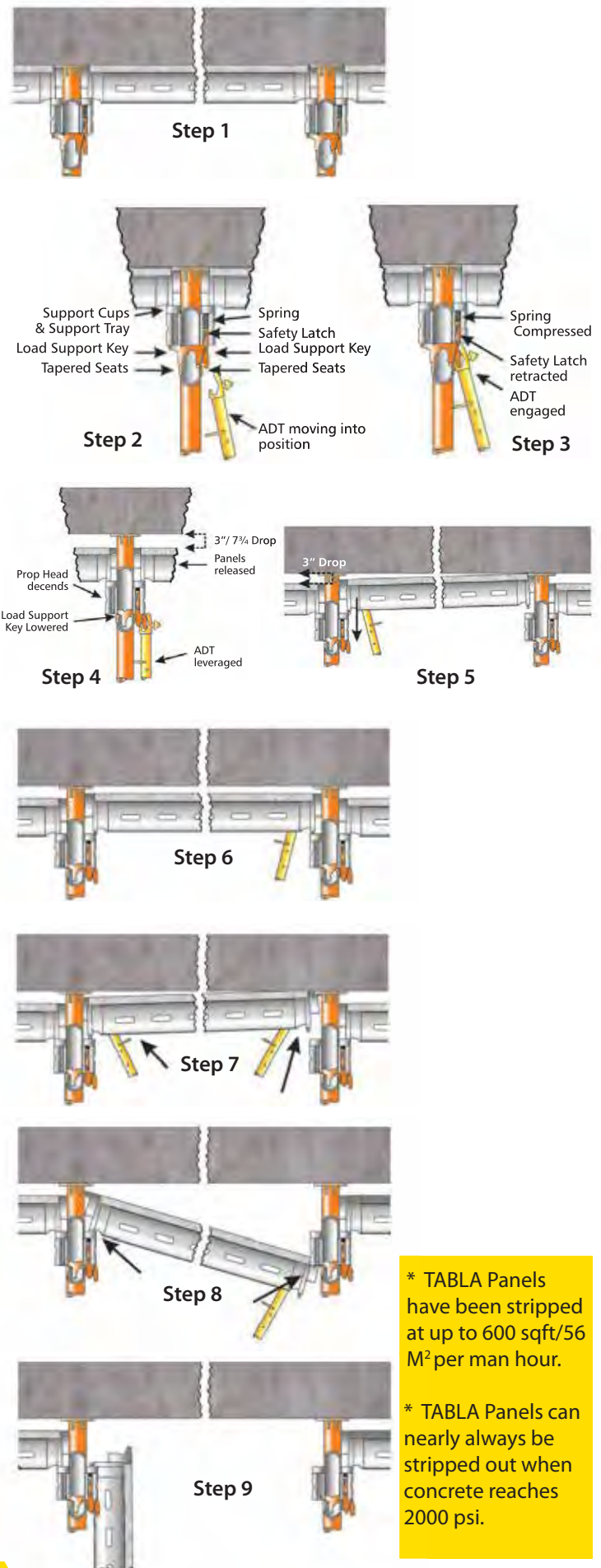

* TABLA Panels have been stripped at up to 600 sqft/56 M² per man hour.

* TABLA Panels can nearly always be stripped out when concrete reaches 2000 psi.

Stripping

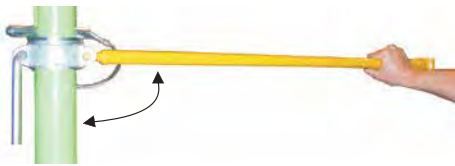
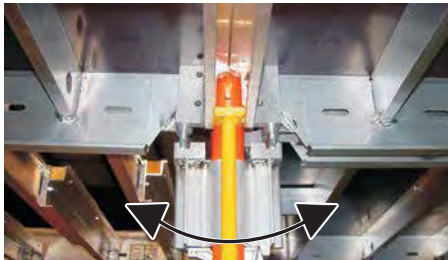
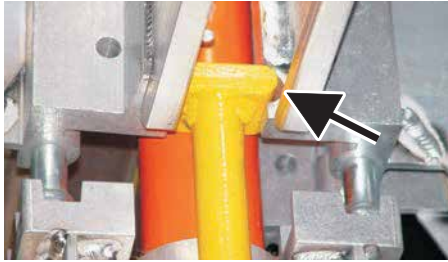

1
Insert Bar into notches on corners of panels.

2
Rotate Bar to release surface tension.

3
Insert Stripping Bar hook into Prop Collar. Rotate collar to raise and lower prop.

Stripping Bar

The TABLA Stripping Bar is a multi use tool, which can be used for the release of surface tension between the Panel Deck and the underside of the slab (see images 1 and 2).

The Stripping Bar can also be used as a "cheater bar" on the Prop Collar. (see image 3).

BUILD STRONG BUILD WITH QUALITY



Stripping Bar.

Inertia Stripping Bar.

Shoring, Backshoring and Reshoring

Typical multifloor construction process

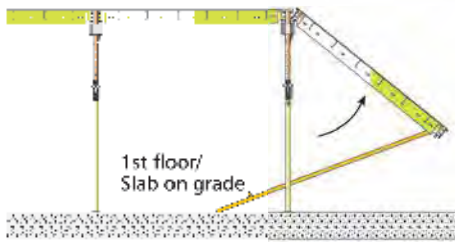

Step 1
Erect TABLA SHORING SYSTEM from floor slab.

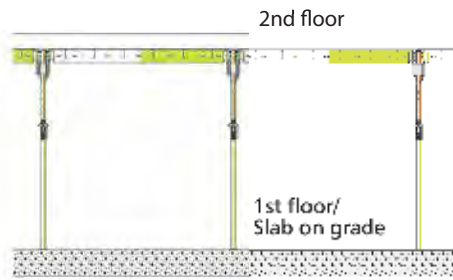

Step 2
Shoring complete, pour second floor.

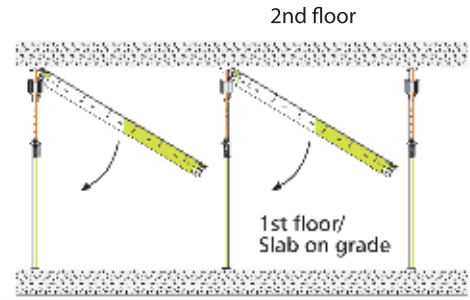

Step 3
Once concrete reaches 2000 psi, remove TABLA Panels. Leave TABLA Props undisturbed.

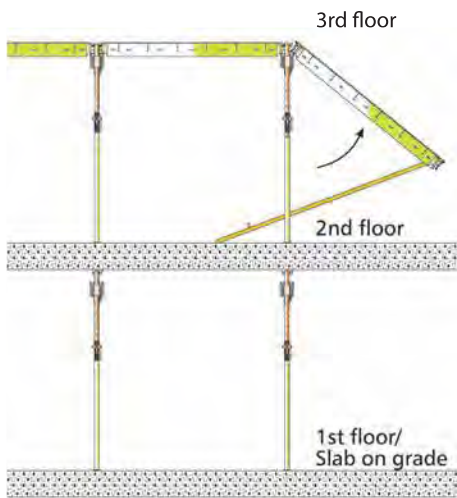

Step 4
Erect third floor with additional Props. Leave TABLA Backprops undisturbed.

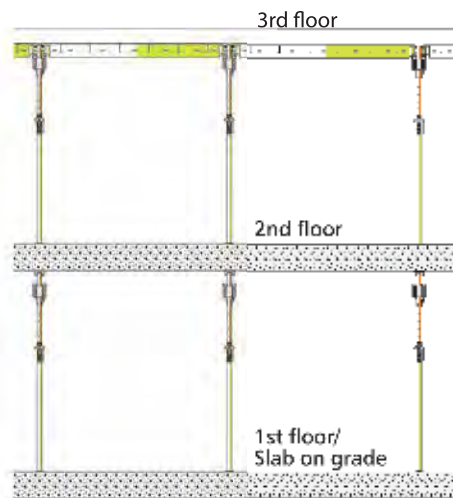

Step 5
Shoring for third floor complete, pour third floor.

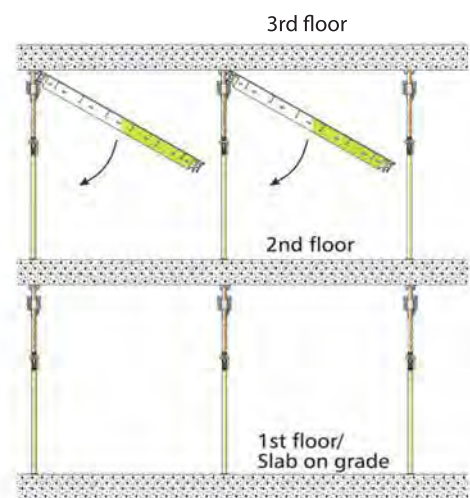

Step 6
Once concrete reaches 2000 psi, remove TABLA Panels from third floor. Leave TABLA Props undisturbed.

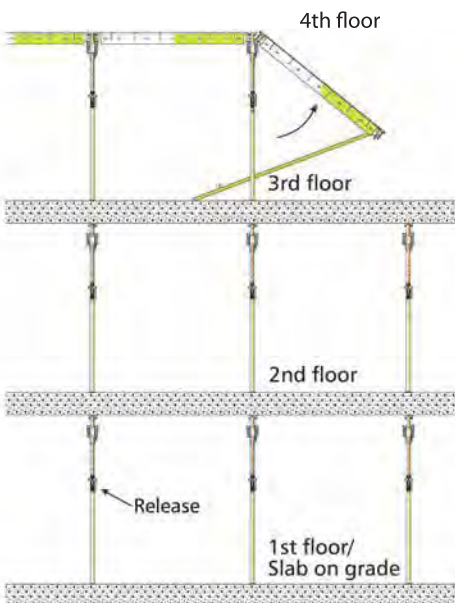

Step 7
Erect 4th floor with additional Props.



Step 8
Convert the lowest level of Props from backshoring to reshoring by striking the Quick Release above the Prop Collar.
Release the load in the section as required by site Engineers. Allow the floor to "Take Up" self weight then snug up the Props.

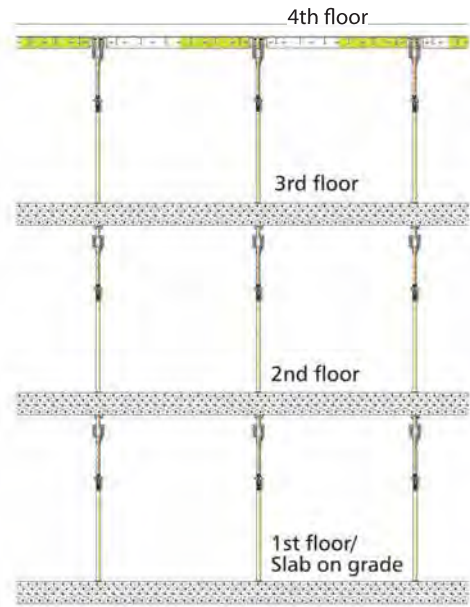

Step 9
Shoring for fourth floor complete, pour fourth floor.

Shoring, Backshoring and Reshoring



BUILD STRONG BUILD WITH QUALITY

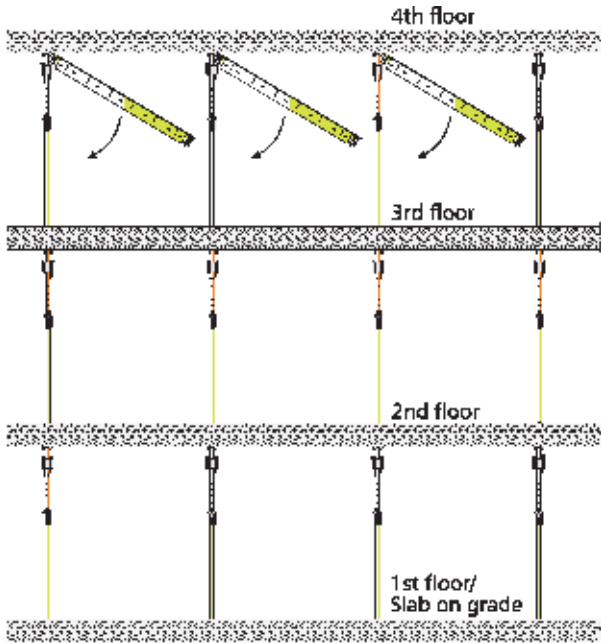

Step 10
Once concrete reaches 2000 psi, remove TABLA Panels from under forth floor. Leave TABLA Props undisturbed.

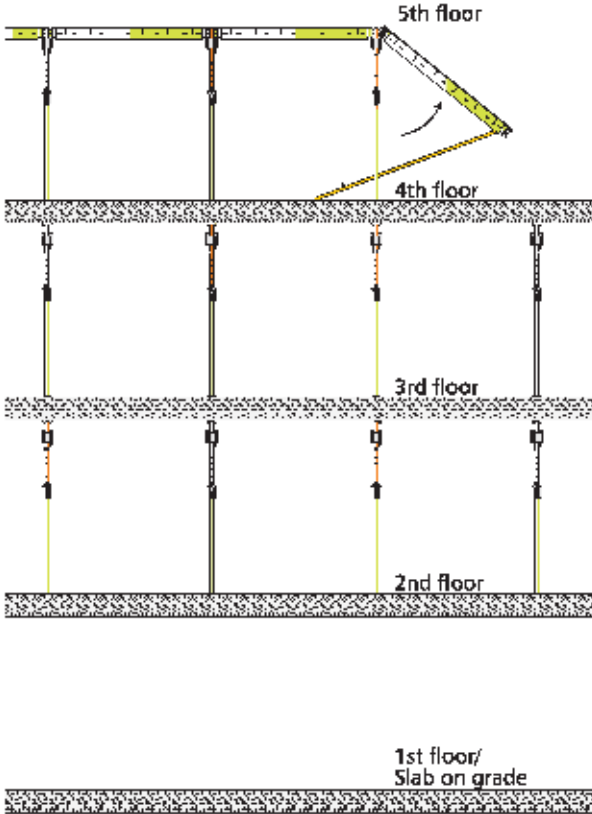

Step 11
Remove Props supporting second floor and recycle them to the forth floor.



TABLA Cantilever System

TABLA's Cantilever technology maximizes efficiency and provides excellent safety on slab edges. **Edge Cantilever construction is a potentially dangerous place to erect and work.** Cantilevered Panels can create a great wind sail and it is estimated that uplift wind on tall buildings can be as high as 40 lbs per sq. ft/195 kg. per square metre or can create a force greater than 120 mph/190k/hr wind. Properly installed, the TABLA Cantilever System is designed to overcome these forces and when used correctly provides a safe working environment along with its unique fast and efficient erection.

Note: Safety chains **MUST** be installed **before** out-board Panels are raised. Safety Toggle Pins are installed with each installation of the Cantilever Post to Panel.

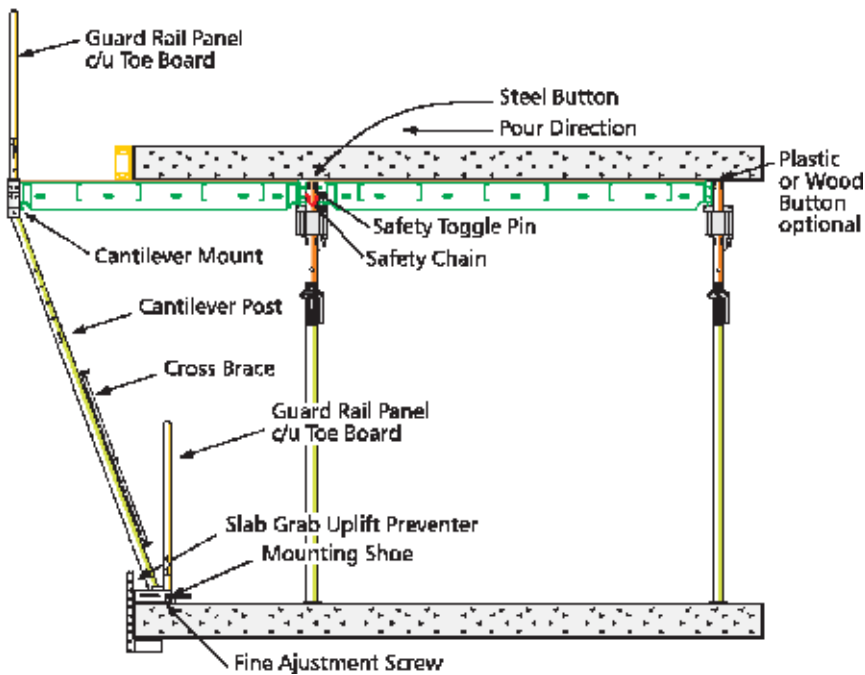
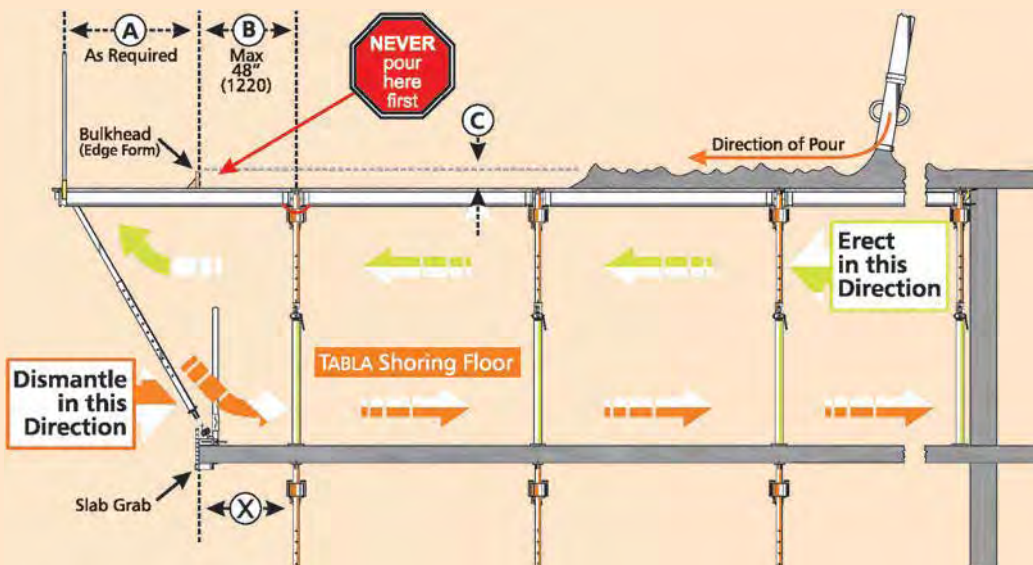

Use personal tie off safety lanyards when working with Cantilevered equipment.

Check drawings for exact details.

For Cantilevers greater than 60 degrees, consult engineering.

Safety Note:

Always be tied off when working with cantilevered panels.

Cantilever Erection

Erection of Cantilever



Edge Mounting Shoe

Step 1

Obtain PPE as per method statement for work and comply accordingly.

Step 2

Hang panel in vertical position and install safety chain (2 per panel) through accessory holes between vertical panel and horizontal panel.

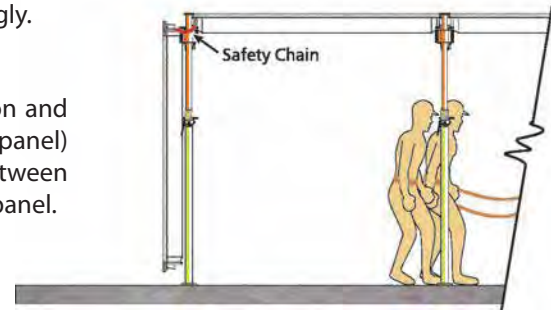

Step 3

Install Cantilever Mounts, Cantilever Posts, Cantilever Shoes, Cross Brace, and upper Guard Rail Panel.

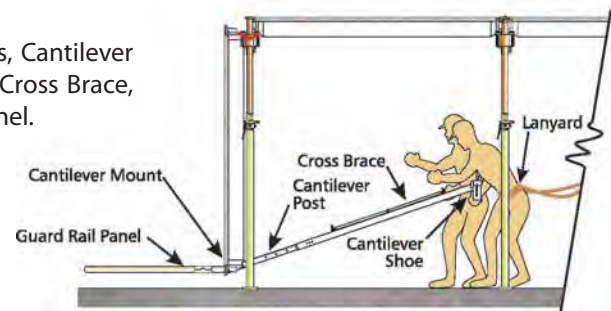

Step 4

After tying off for personal protection, rotate panel into horizontal position using Cantilever Posts.

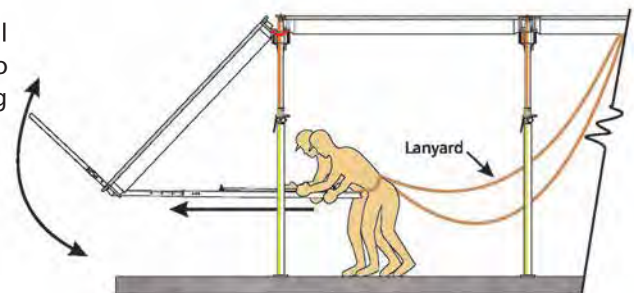

Step 5

Install Cantilever Shoe, securing it with a Slab Grab, then install the Cross Brace and Guard Rail.

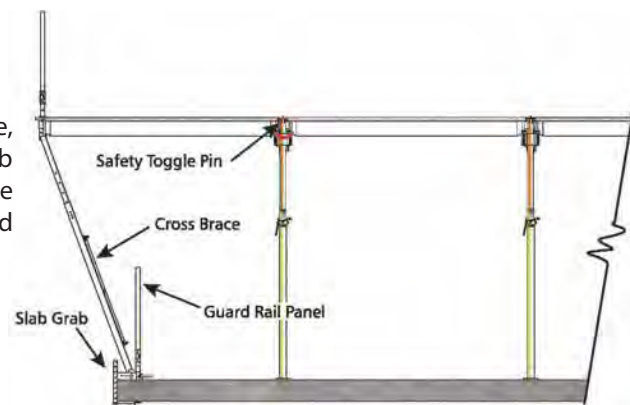

Cantilever Stripping

Stripping procedure for reinforced concrete Cantilevered Panel

- 1 Leave safety chains in place and remove Safety Toggle Pin. Release the Load Support Key using the ADT Tool and drop the Panel.
- 2 While tied off with your Safety Lanyard, remove the lower Guard Rail.
- 3 Free The Mounting Shoe from the slab.
- 4 Using the Cantilever Post, rotate the Panel downward into the vertical position.
- 5 Remove the remaining Cantilever components and recycle them to the next floor.

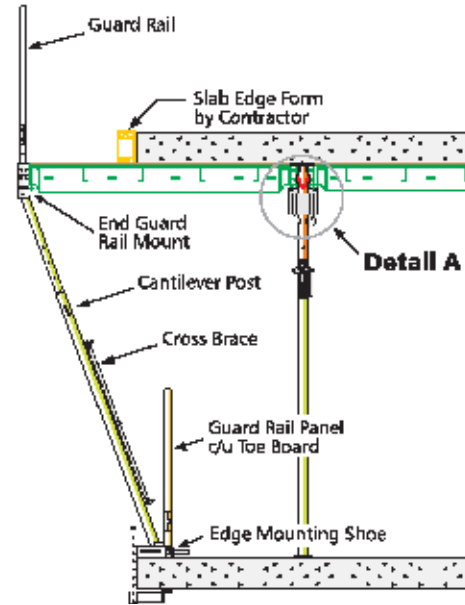

Detail A Poured Position

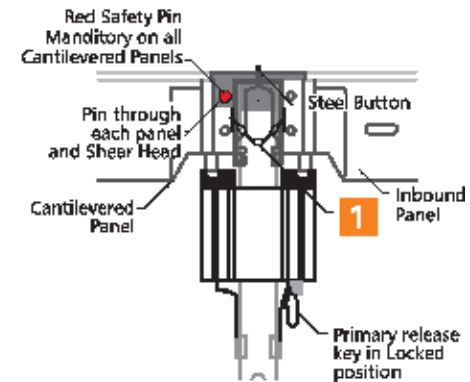

- 1 Safety chains, 2 per panel, in place between Cantilever Panel and Inward Panel. Place through accessory holes on end rails of Panels prior to the erection of Cantilevered Panel.



Stripping Procedure

Stripping procedure for post-tensioned Cantilevered Panel

- 1 Once concrete is up to panel stripping strength, release primary Release Key on the interior Props and lower Cup and Sleeve assembly.
- 2 Release primary Release Key on exterior Props adjacent to Cantilever Post. Lower Cup and Sleeve assembly. Cantilevered Panel end drops only 1/8". Inbound Panel drops 3". See **Detail B**.
- 3 Swing down inbound Panel and remove Safety Chains from inbound Panel only. Wrap Safety Chains around postshore linking them using the chain connector link. See **Detail C**. Lift inbound Panel out of Cups and remove from area.
- 4 After slab is post-tensioned and Cantilevered Panel is ready to be stripped, remove one pair of chains which are wrapped around postshore. Make sure Cantilevered Panel being stripped has one Safety Chain through it and is connected to other Panel around postshore.
- 5 Remove Shear Pins through Cantilevered Panel by pushing upward on panel 1/8". Swing Panel down into hanging position. Remove remaining Safety Chain and lift panel out of Cups. Do one Panel at a time. Repeat step 4 and 5 for the remaining Panels.

- 2 Swing inbound panel down and disconnect safety chains from it. Link safety chains together around postshore using chain connector link.

- 3 Safety chains, 2 per panel, in place between Cantilever Panel and Inward Panel. Place through accessory holes on end rails of Panels prior to the erection of Cantilevered Panel.



BUILD STRONG BUILD WITH QUALITY

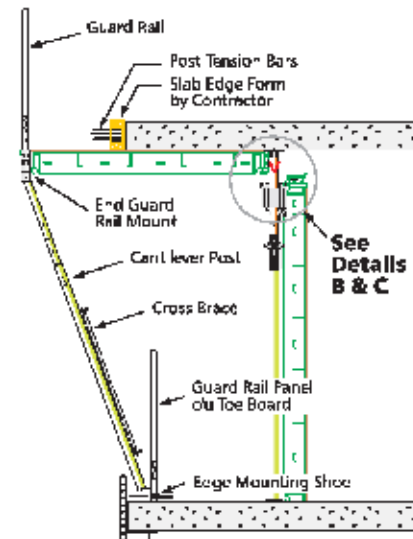

Detail B

Inward Panels Dropped.

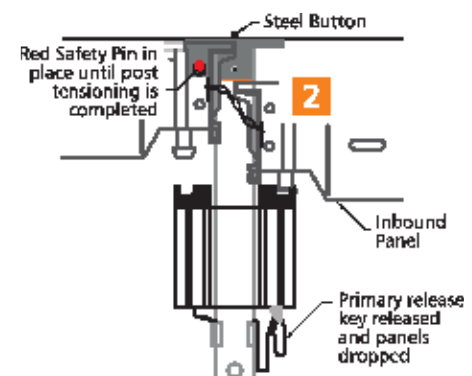

Detail C

Inbound Panel Swung Down, Safety Chains Connected.



TABLA Cantilever Red Safety Chain.

Ramps

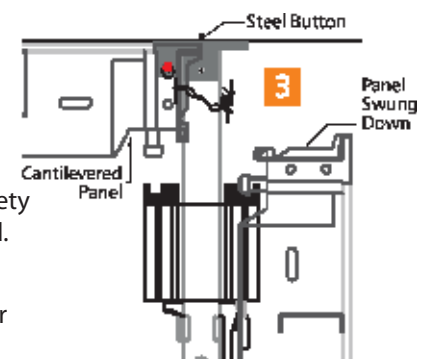

Concrete being pumped onto typical ramp constructed using TABLA Shoring.

The TABLA Shoring System has the unique ability to be used on ramps. To the right is a typical example of ramp erection.

Please note that terminus Shear Plate must be anchored to the concrete slab before a dead or live load is placed on TABLA Panels. Additional bracing is not required under sloped areas in single Prop arrangements of TABLA, provided that Shear Anchors or Shear Braces are firmly in place, and Panels are blocked at existing walls and columns (see layout drawings).

Shear load is accumulative when concrete is poured from top down. These calculations are based upon uphill pours. Consult the TABLA Engineering Department if poured downhill.

For conditions not shown in this brochure and or the Engineering Bulletin, contact the TABLA Engineering Department (TED).

When extreme conditions exist between slopes on the supporting slab and the supported slab, contact the TABLA Engineering Department.

When the supporting floor is not at the same slope as ramp above, wedges must be provided to maintain full bearing across the base plate.

Typical Ramp

BUILD STRONG BUILD WITH QUALITY

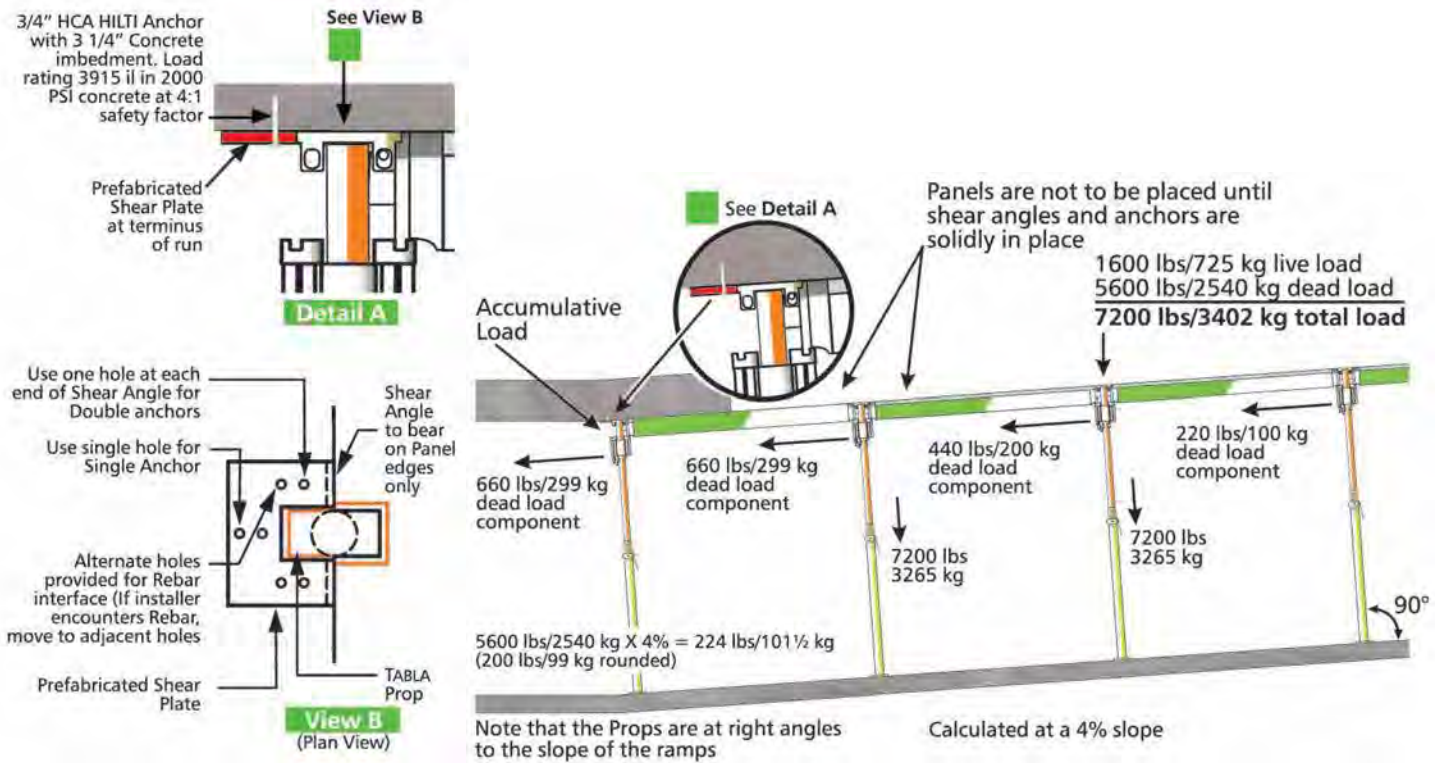

Alternate Ramp with Diagonal Shear Brace



Tabla Props must be shimmed with wedges to plumb for level deck above a ramp incline.

High Floor Shoring System

TABLA Pioneer is a high floor shoring system which allows you to go to any height (subject to shoring tower specifications). It can be erected using TABLA's Pioneer Head Assembly (Detail 1) or TABLA Prop (Detail 2). Either configuration can be attached to most standard shoring frames using TABLA's Pioneer Connector. The system allows for stripping of the Panels while backshoring remains undisturbed. The new TABLA Quick Release Reshore Base (Detail 3) attaches to most screwjacks using TABLA's Pioneer Screw Adaptor. This allows the system to provide shoring, backshoring and reshoring using the same principal as TABLA's Standard Shoring System. See pages 6 and 7 for more information regarding Backshoring and Reshoring.

Erection

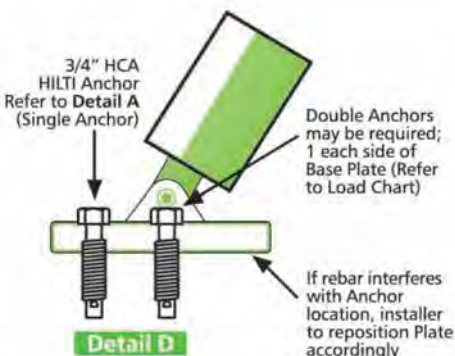
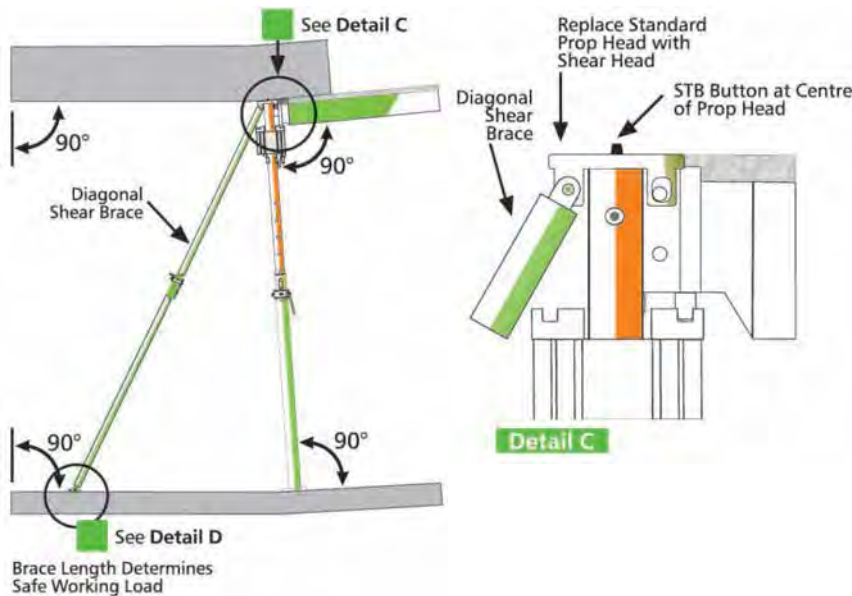
- 1 Erect shoring towers using TABLA Panel spacing
- 2 Remove Head Plate from Pioneer Head Assembly or TABLA Prop
- 3 Connect Pioneer Head Assembly or TABLA Prop to top of shoring frames
- 4 Drop TABLA Panels into position from above, snap in TABLA Prop Heads, then pour the floor
- 5 Once concrete reaches 2000 psi, and in accordance with ACI, strip TABLA Panels

Note: TABLA advise the use of a safe access system for this work.



Consult TABLA's Engineering Department for more information TABLA Pioneer.

TABLA Pioneer System

BUILD STRONG BUILD WITH QUALITY

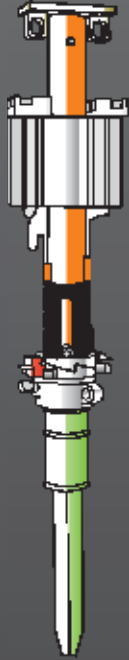

Detail 1

Pioneer Head Assembly

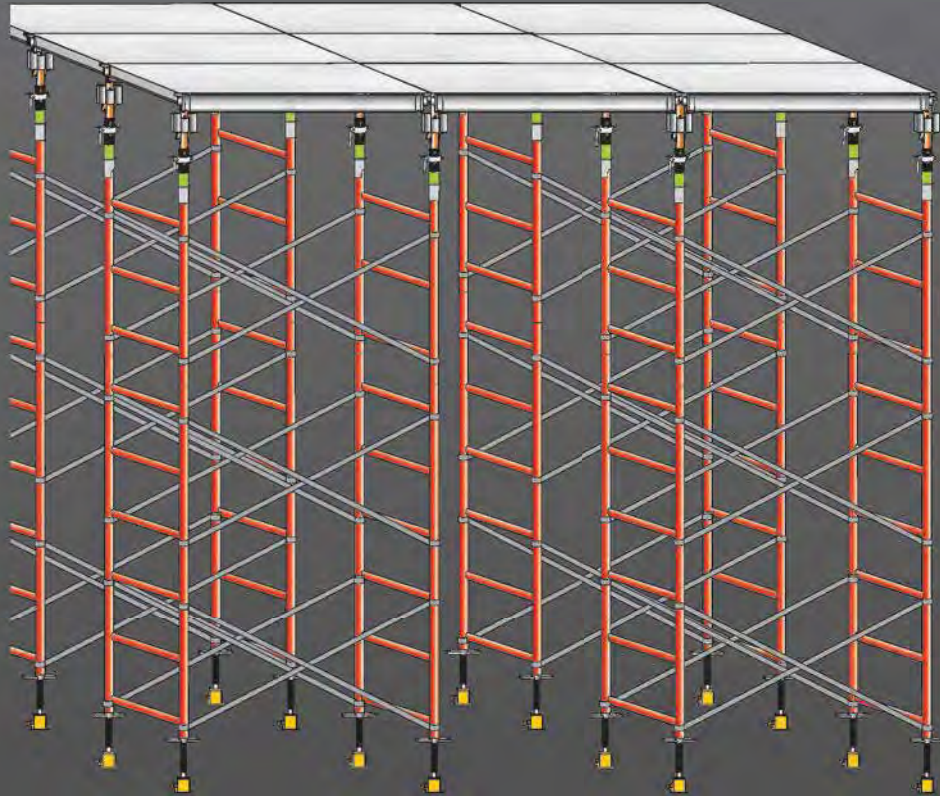

Shown with Pioneer Head Assembly (see Detail 1)



Detail 2

Tabla Prop

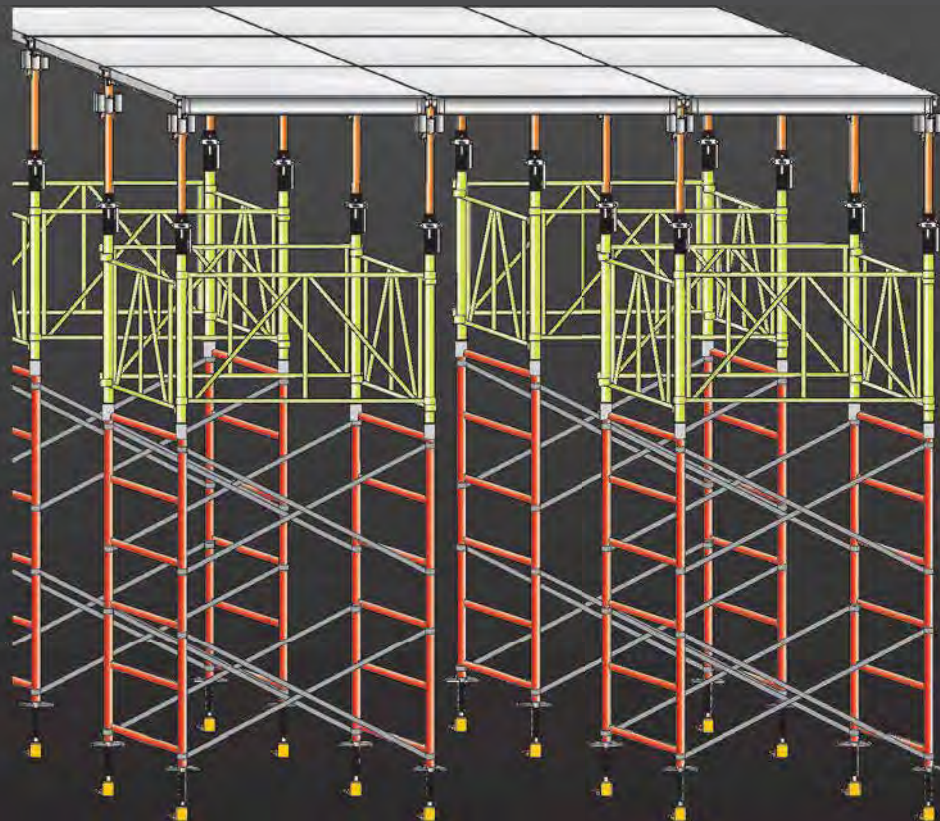

Shown with the Table Prop (see Detail 2)

Infill components



TABLA Infill Components

TABLA infill Components are designed to bridge between Panels or between Panels, walls and columns.

Construction workers are using Side and End Filler Beams along with the Telescopic Beam they are holding to infill around a column at a project in Biola.



Side Filler Beam



End Filler Beam



Gravity Lock

Side and End Filler Beams

Side and End Filler Beams allow 3/4" plywood to infill to the side of the Panel. The benefits of using Side and End Filler Beams are :

- Provide nailer strip for connecting 3/4" plywood;
- Eliminates notching of plywood around Post Shore Heads;
- Eliminates eccentric loading on Prop;
- Colour coded* for quick identification between Side and End Rails of Panels - simply match colours during erection.

Place the Filler Beam into the Prop Cup and secure it using the TABLA Gravity Lock through accessory holes of the Panel and Filler Beam.

*Colours are reversed for metric sizes.

Telescopic Beams

Telescopic Beams

TABLA Telescopic Beams are light weight and have an excellent load capacity. They are designed to take Drop Heads and Infil Strips from 3'0"/914 to 10'0"/3050. Telescopic Beams connect directly to the Filler Beams. These Beams are equipped with a graduated Bearing Plate at each end. Each Bearing Plate consists of 5 gravity bearing seats in 1" increments. By using the lowest seat the TABLA Telescopic Beam forms a flush deck using $\frac{3}{4}$ " 19 mm plywood infill. Other levels are for change in slab thickness and Drop Heads.

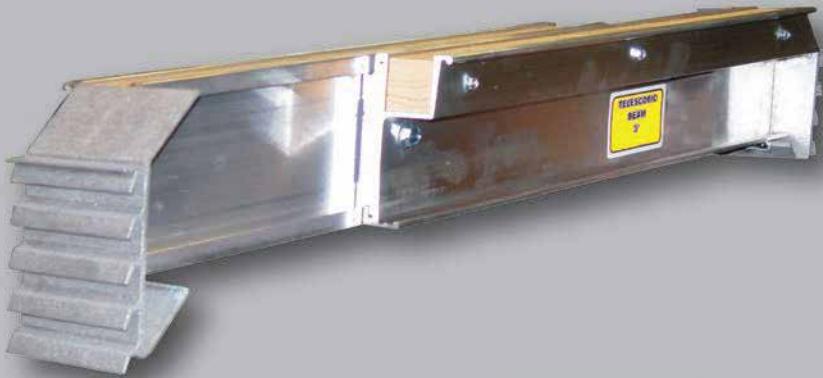

Telescopic Beams



Telescopic Beams

BUILD STRONG BUILD WITH QUALITY

For deeper drops of the Telescopic Beam use the Telescopic Beam Extension.



Beam Extension

Use Telescopic Beam Hanger to connect to wall or column ledger.



Beam Hanger

Supplemental Support

In cases where the load or the drawing requires for "supplemental support", the recommended procedure is as illustrated. At all times make sure that when installing the supplemental supports they do NOT lift the gravity seats out of the edge support.

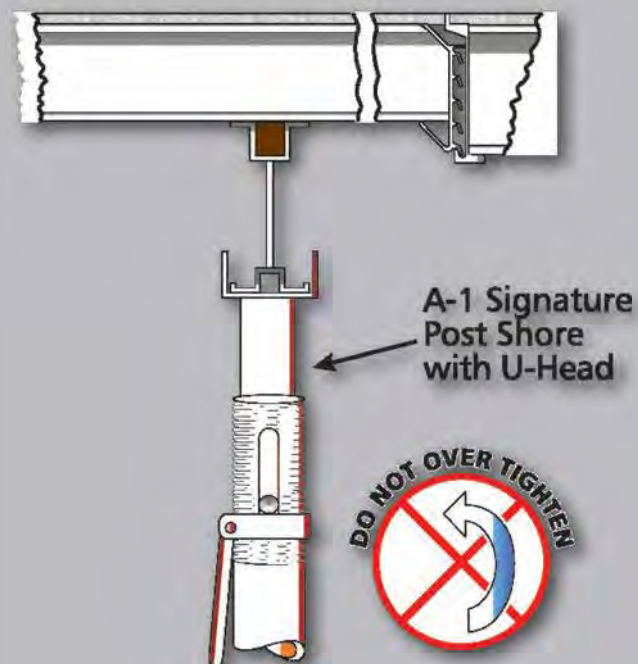

Telescopic Beam supported at mid-span with "U-Head" Post Shore.

Do not over tighten post shore & lift up formwork.
Carpentry formwork by Contractor.
Check drawings for exact details. Telescopic Beams may need supplemental supports.
Always refer to Engineering drawings for the Telescopic Beam spacing and supports.

Stripping of TABLA Panels Report



Ramon J. Cook, P. E.

913 Dimrock Drive
Phone: 210-659-0022

Schertz, Texas 78154
E-mail: ramoncookpe@sbcglobal.net

Stripping of TABLA Panels from under Green Concrete Reinforced Concrete or Post Tensioned Concrete / Pre-Tension

When it is desirable or required to strip (remove) TABLA Panels from under recently poured concrete, it is acceptable to do so under the following conditions.

- 1) The ambient temperature under the slab must be no less than 45 F (7 C) – naturally or artificially maintained.
- 2) The tested strength of a slab poured and cured cylinder must be at least 2,000 PSI.
- 3) The grid spacing (size / dimensions) must not exceed 8' x 4' panel / prop spacing (2,500mm x 1250mm).
- 4) The TABLA Prop head must not at this point be disengaged from the curing concrete slab, avoiding stripping shock.
- 5) Until the concrete cylinder strength exceeds 2,500 PSI, construction loads on the suspended slab must be limited to no more than 20 lbs per sq ft (9.0 kg) between the TABLA Props (Backprops) supporting this slab.
- 6) Continue to cure concrete in accordance with jobsite specifications.
- 7) Leave TABLA props undisturbed until contract specification concrete strength is gained.
- 8) This bulletin pertains only for use where TABLA System undisturbed BackPropping is employed, and is not intended to be interpreted as applying to the jobsite as a whole.

This bulletin is a synopsis of an overview by engineer Ramon Cook P.Eng. If more information is required contact Art Magee, TABLA Engineering Department (TED) at TED@TablaShoring.com here to arrange consultation with Mr. Cook.



2006 P.E. Licenses: Delaware = 6119; District of Columbia = 7543; Maryland = 12521; Virginia = 13351; Georgia = 17268; Texas = 22830; New Jersey = 28480

Ramon J. Cook, P. E.

913 Dimrock Drive
Phone: 210-659-0022

Schertz, Texas 78154
E-mail: ramoncookpe@sbcglobal.net

18 April 2006

Mr Paul Gillespie, President
Gillespie Practical Technologies, Inc
Toronto, Ontario Canada

Re: TABLA Reshore Safety Factor

Safety Factors of shoring: supports for concrete forms under unstable wet weights; have long been required to adhere to minimum limits of 2.5/1.0 for framed shoring and 3.0/1.0 for single post shoring. TABLA takes no exception to this rule.

TABLA standard post shore rating is 7,200 lbs each, when plumb, under braced panel arrays, and extended to 12'-0" max height, with 3/1 Factor of Safety on ultimate strength.

OSHA, ANSI A10.9, and ACI 347 are all silent on the subject of Safety Factors for RESHORES of dry weights. ACI 347.2R-05, Shoring/Reshoring of Concrete Multi-Story Buildings says "Where manufactured shores/reshores are used, the manufacturer's data should be consulted for safe working loads and other safety requirements of the shores/reshores and hardware." (Section 5.1.5, Adequacy of shoring/reshoring system)

GPT has chosen a safety factor for RESHORES of 1.7 based on the structures own design load factors. These are given in SEI/ASCE 37 as 1.2 for dead loads, 1.4 for all loads, and 1.6 for construction live loads. Dead load of TABLA shoring/reshoring system is so light in comparison to construction slab & superimposed construction forces being carried (which equal to "live loads", as far as reshoring is concerned) that the total factor = 1.7 was chosen by GPT as a legitimate load factor for practical design purposes and jobsite safety.

This is tenable because the reshores are standing on a braced surface: a completed slab is braced into its building structure, or it wouldn't be able to support reshores! In addition, the slab above being propped is stable, also tied into its columns and walls, or it couldn't have been stripped of forms to be reshored. So, it only remains for the reshores to be stable at ceiling heights per ACI's spec: "manufacturers' data". TABLA post shores were tested per SSFI methods to obtain that verified strength-to-height data.

Respectfully submitted,

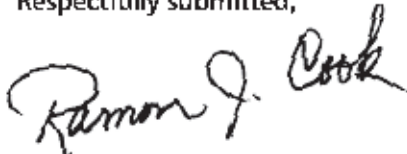

Ramon J. Cook, P. E.



2006 P.E. Licenses: Delaware = 6119; District of Columbia = 7543; Maryland = 12521;
Virginia = 13351; Georgia = 17268; Texas = 22830; New Jersey = 28480

Panel Strip Time Report



Ramon J. Cook, P. E.

913 Dimrock Drive
Phone: 210-659-0022

Schertz, Texas 78154
E-mail: ramoncookpe@sbcglobal.net

TABLA Panel Strip Time Report

31 Mar 2006

Gillespie Practical Technology has invented a slab form and shore system which has a firm root in existing and traditional ACI documents.

The TABLA system combines

- 1.) **Shoring:** support of wet weight and placing loads; with
- 2.) **Reshoring:** support of curing or dry weight.

In ACI 347R-04 definition, stripping the panels out separately from their shoreposts equals the "Backshoring" method of floor construction. "Backshoring" is defined in 347's document as stripping out ONLY SMALL AREAS of form, and immediately placing reshores so "the slab does not deflect and carry its own weight" alone. Backshoring has been found by long practice as satisfying the need for form removal while maintaining immediate green slab support. Thus, structurally, the TABLA panel-removal method does not strip TABLA prop supports, while it does permit the Contractor to get out the panels alone.

With props in place, as-cast, no slab is allowed to deflect and transfer its own weight to beams and columns. Nor, is any beam on TABLA shoring allowed to transfer its own weight to columns and walls. Both are completely supported according to Code. Soffit areas are subject to curing spec's and top live load limits (20 psf, overall average, max), of course.

TABLA shoring patterns are the same for any slab thickness: 4 ft x 8 ft max. The concrete green strength needed before panel strip depends on concrete tensile capacity for post punching shear and "unreinforced bending (per tilt-up standard practice) rather than traditional compression strength. If compression strength is in the range of 2000 psi, and modulus of rupture (beam test) tensile strength in the range of 250 - 300 psi, then panels may be stripped. If these levels can't be guaranteed, the panels must stay in place until they are known and guaranteed.

At all times, Owner's specification minimum concrete compression strength stripping time in contract documents does apply to TABLA prop removal, however.

"Reshoring" is another process, totally separate from TABLA panel removal. TABLA props may be reshores, also, and often are. But, other reshoring methods are available, and are not germane to the subject of "getting out panels earlier than props".

Respectfully submitted,

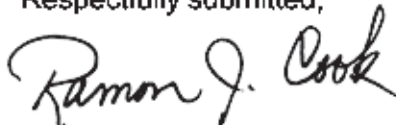
Ramon J. Cook, P. E.



2006 P.E. Licenses: Delaware = 6119; District of Columbia = 7543; Maryland = 12521;
Virginia = 13351; Georgia = 17268; Texas = 22830; New Jersey = 28480

Ramon J. Cook, P. E.

913 Dimrock Drive
Phone: 210-659-0022

Schertz, Texas 78154
E-mail: ramoncookpe@sbcglobal.net

TABLA Panel Strip Time Report

31 Mar 2006

Addendum & References:

Panel removal flexure considerations:

The distance at which "full flexure" deflection vs "shear-block" deflection takes place is in the span/depth range of 32 to 1. This means a "span" of 32 times thickness. Under an 8" slab, for example $32 \times 8" =$ about 21 feet, or 6.3 m is required before "flexure" as measured by "standard" calculation methods can occur. "Span" is figured from outside a support half-slab-depth, when supports are not theoretical knife-edges. TABLA max spans are only 11 to 1 span/depth ratio with panels removed, and flexural support widths are over 20% of clear spans. These geometries make TABLA supports far wider in ratio to span than simple "pin" or "knife-edge" bearings.

The TABLA prop system firmly supports slabs and beams in a direct, fool-proof pattern of exact placement and test-proven strength, during pour, during cure, and during reshore conditions. No reports of premature green-cracking of slabs after panel removal have been received from the many jobs this system has supported, when proper curing of that green concrete has been applied.

In short, TABLA props hold up green slabs with full-contact support at every shore head before, during, and after panel removal. TABLA props do it without drop-head shock, without delay in reshore placing, without error in reshore location, and without variations in plumb and preload...

Many Specifications haven't quite caught up with this new TABLA system.

References:

1. ACI 347 – 04, Section 3.5.1, Shoring:
Section 3.7.2.1, Removal of forms & supports;
Section 3.8.3, Other methods (backshoring)
2. ACI SP-4 7th Ed, Section 6, P35, Shoring design, "Other Patented Shoring Devices"
3. op cit: P35, and "Multistory Work", particularly the recommendation for removal of ALL forms & shores at 70% f_c specified minimum 28-day concrete ultimate strength. (Note: This does NOT mean removal of panels, leaving props in place, the TABLA Method)
4. op cit: P35, Table 6-9B, "obtain project-specific age-strength data for the mix and job conditions with which they are working"
5. op cit: Section 6, P37, Table 6-4A

Assessment of Minimum Cube Strength for Striking TABLA Forms



3rd April 2008

Paul Gillespie CEO
Tabla Shoring Systems
1541 Hurontario Street
Mississauga,
Ontario, Canada L5G 3H7

Galwally Lodge
4 Saintfield Road
BELFAST
BT8 6AA

Tel: 028 9064 4655
Fax: 028 9064 4744
Email: info@mcfni.co.uk
consult@ppf.co.uk

Dear Mr Gillespie

Assessment of Minimum Cube Strength for Striking Tabla Forms

Further to our discussion we have examined limiting factors in the performance of a 200mm thick concrete slab under the following conditions (a) supported on a 2.4m x 1.2m Shore Grid, (b) assumed to contain the minimum area of tensile reinforcement allowable under the design code and (c) subject to a construction loading of 2.5KN/sq.m (~ 50 lbs/ft²).

Three conditions were checked for lower-bound slab capacity, based on a shore-head plate size nominally 150mm x 80mm on plan and using conservative analysis and design in accordance with BS8110

- 1 Capacity based on flexural resistance of steel in tension.
- 2 Capacity based on flexural resistance of concrete in compression.
- 3 Capacity based on shear resistance of concrete.

Of these, punching shear, during the early low-strength phase of the curing concrete, is the limiting condition and based on our calculations the concrete strength, below which punching shear failure is critical, is around 5.0N/mm² (750 psi). Above this strength, punching shear resistance rapidly improves and the slabs lower-bound capacity switches to being governed by the minimum area of tensile reinforcement, which provides more than sufficient capacity for load transfer the shore heads.

However, in arriving at a suitable minimum strength at which the Tabla panels can be struck while leaving the shore prop undisturbed, account needs to be taken of the dynamics at the instant of load transfer during the striking operation and of uncertainty due to the fact that very early strength is not necessarily consistent throughout in a large area of slab.

As such we would suggest that 13.0N/mm² (1950 psi) is a safe and satisfactory strength at which the Tabla forms can be struck under normal temperate conditions. It could in our view be less, where ambient conditions are conducive and where more certainty with regard to the quality of site and mix design control is qualified and in evidence, but under no circumstances should the cube strength be less than 10.0N/mm² (1500psi).

We trust that this is helpful and should you require any further comment please do not hesitate to contact us.

Yours sincerely

Felix James Magee
On behalf of MCF Consulting

© MCF Consulting Ltd 2008. All rights reserved. www.gordonsmith.co.uk/2008/04/03/08



Partners: Felix Magee Sydney Cranston Peter Scott
Consultant: Peter Fitzpatrick

Magee Cranston Fitzpatrick

Consulting Civil and Structural Engineers
Incorporating Fitzpatrick Consulting (NI) Limited



TABLA System Components



AL DHABI SCAFFOLDING & FORMWORK LLC

BUILD STRONG BUILD WITH QUALITY





Panels, Props and ADT in use at a construction site in Washington.



TP64R



TP1812R

Russian Plywood Panels

Code	Component	ft
P42	Panel	4x2
P62	Panel	6x2
P82	Panel	8x2
P44	Panel	4x4
P64	Panel	6x4
P84	Panel	8x4

Russian Plywood Metric Panels

Code	Component	mm
P126	Panel	1200x600
P186	Panel	1800x600
P246	Panel	2400x600
P1212	Panel	1200x1200
P1812	Panel	1800x1200
P2412	Panel	2400x1200

Russian Plywood Transition Panels

Code	Component	ft
TP44	Transition Panel	4x4
TP84	Transition Panel	8x4
P246	Transition Panel	Left Hand 6x4
P1212	Transition Panel	Right Hand 6x4

Russian Plywood Transition Metric Panels

Code	Component	mm
TP1212	Transition Panel	1200x600
TP2412	Transition Panel	2400x1200
TP1812L	Transition Panel	Left Hand 1800x1200
TP1812R	Transition Panel	Right Hand 1800x1200

Props

Props

Code	Component	ft	mm
P10	Prop	0'10"	3124
P12	Prop	0'12"	3658
PE	Prop Extension	6'4"	1372
PE	Prop Extension	6'2"	762

Pioneer

Code	Component
PH	Pioneer Hand

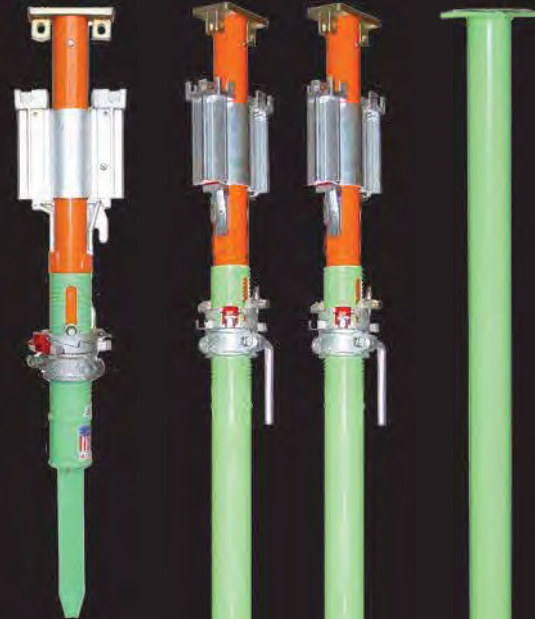

PH
Pioneer
Head

P10
Prop

P12
Prop

PE
Prop
Extension



Beams and Hangers

Filler Beams

Code	Component	ft
EF2	End Filler	2
EF4	End Filler	4
SF4	Side Filler	4
SF6	Side Filler	6
SF8	Side Filler	8
FB(2x4)	Filler Bracket (2x4) 3 Way	
UGL	Universal Gravity Lock	

Metric Filler Beams

Code	Component	mm
EF6	End Filler	600
EF12	End Filler	1200
SF12	Side Filler	1200
SF18	Side Filler	1800
SF24	Side Filler	2400
FB(2x4)M	Filler Bracket (2x4) 3 Way	
UGL	Universal Gravity Lock	

Telescopic Beams

Code	Component	ft
TSB3	Telescopic Beam	3
TSB5	Telescopic Beam	5
TSB10	Telescopic Beam	10

Metric Telescopic Beams

Code	Component	mm
TSB3	Telescopic Beam	914
TSB5	Telescopic Beam	1524
TSB10	Telescopic Beam	3048

Swivel Telescopic Beams

Code	Component	ft
TSB3S	Swivel Telescopic Beam	3
TSB5S	Swivel Telescopic Beam	5
TSB10S	Swivel Telescopic Beam	10

Metric Swivel Telescopic Beams

Code	Component	mm
TSB3S	Swivel Telescopic Beam	914
TSB5S	Swivel Telescopic Beam	1524
TSB10S	Swivel Telescopic Beam	3048

Telescopic Beam Hanger

Code	Component
TBH	Telescopic Beam Hanger

Metric Telescopic Beam Hanger

Code	Component
TBDE	Telescopic Beam Drop Extension

EF4
End Filler Beam



SF4
Side Filler Beam



EF12
Metric End Filler Beam



SF12
Metric Side Filler Beam



FB 2 x 4
Filler Bracket 2 x 4 3-way



UGL
Universal Gravity Lock



TSB5
Telescopic Beam



TSB5S
Swivel Telescopic Beam



TBH
Telescopic Beam Hanger



Cantilever, Guard Rail, Post and Gate Brace



CP
Cantilever Post



CPE
Cantilever Post Extension



EMS
Edge Mounting Shoe

Cantilever

Code	Component
CP	Cantilever Post
CPE	Cantilever Post Extension
EMS	Edge Mounting Shoe
SGR	Slab Grab
EPC	End Panel Connector
SPC	Side Panel Connector



SG
Slab Grab



EPC
End Panel Connector



SPC
Side Panel Connector



GRP
Guard Rail Post



GR4
Guard Rail Panel



GRPC
Guard Rail Post Connector

Guard Rail Panel and Post

Code	Component	ft
GRP	Guard Rail Post	4.5
GR4	Guard Rail Panel	4.0
GR6	Guard Rail Panel	6.0
G R8	Guard Rail Panel	8.0
GRPC	Guard Rail Prop Connector	

Metric Guard Rail Panel and Post

Code	Component	mm
GRP	Guard Rail Post	1372
GR12	Guard Rail Panel	1200
GR18	Guard Rail Panel	1800
GR24	Guard Rail Panel	2400
GRPC	Guard Rail Prop Connector	

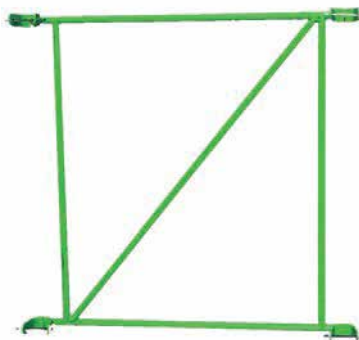

GB4
Gate Brace

Gate Brace

Code	Component	ft
GB4	Gate Brace	4
GB6	Gate Brace	6
G B8	Gate Brace	8

Metric Gate Brace

Code	Component	mm
GB12	Gate Brace	1200
GB18	Gate Brace	1800
GB24	Gate Brace	2400

Stripping Bar and AD Tools

Tools

Code	Component
ADT	Assembly and Disassembly Tool
ADTLH	Long Handle for ADT
SB	Stripping Bar
ISB	Inertia Stripping Bar



SB
Stripping Bar



ISB
Inertia Stripping Bar



ADT
Assembly and Disassembly Tool



BUILD STRONG, BUILD WITH QUALITY



ADX AluPanel Formwork System

